

【FIR フィルタ FIR Filter】

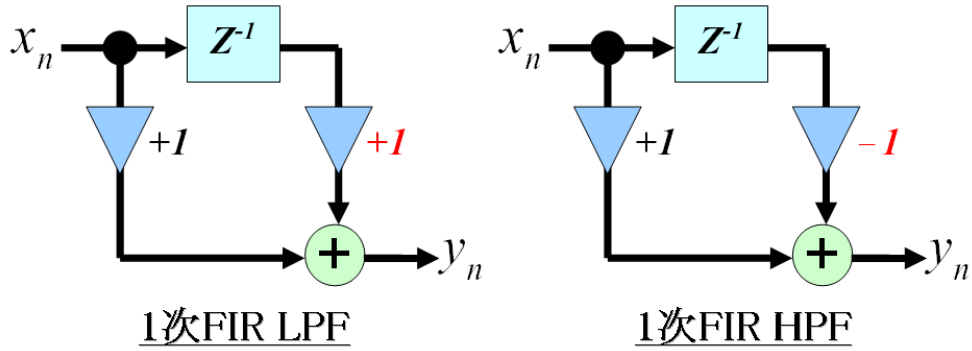

■ 1次 FIR LPF

差分方程式： $y_n = x_n + x_{n-1}$

伝達関数 Z 変換： $H(z) = \frac{Y(z)}{X(z)} = 1 + z^{-1}$

周波数特性： $H(\omega) = H(z)|_{z=\exp(j\omega T)} = 1 + e^{-j\omega T} = e^{-j\frac{\omega T}{2}} 2\cos(\frac{\omega T}{2})$

$|H(\omega)| = 2\cos(\frac{\omega T}{2}) \quad \because |e^{-j\frac{\omega T}{2}}| = 1, 0 \leq \omega T \leq \pi$

■ 1次 FIR HPF

差分方程式： $y_n = x_n - x_{n-1}$

伝達関数 Z 変換： $H(z) = \frac{Y(z)}{X(z)} = 1 - z^{-1}$

周波数特性： $H(\omega) = H(z)|_{z=\exp(j\omega T)} = 1 - e^{-j\omega T} = e^{-j\frac{\omega T}{2}} \cdot 2j\sin(\frac{\omega T}{2})$

$|H(\omega)| = 2\sin(\frac{\omega T}{2}) \quad \because |e^{-j\frac{\omega T}{2}}| = 1, 0 \leq \omega T \leq \pi$

■ 3次 FIR BPF

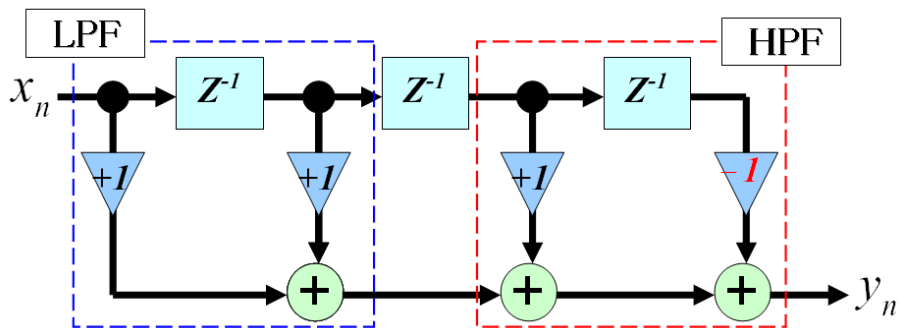

LPF と HPF で構成.

差分方程式： $y_n = x_n + x_{n-1} + x_{n-2} - x_{n-3}$

伝達関数 Z 変換： $H(z) = \frac{Y(z)}{X(z)} = 1 + z^{-1} + z^{-2} - z^{-3}$

周波数特性

$$\begin{aligned}
 H(\omega) &= H(z)|_{z=\exp(j\omega T)} = 1 + e^{-j\omega T} + e^{-2j\omega T} - e^{-3j\omega T} = e^{-j\frac{\omega T}{2}} (e^{j\frac{\omega T}{2}} + e^{-j\frac{\omega T}{2}}) + e^{-2j\omega T} (1 - e^{-j\omega T}) \\
 &= e^{-j\frac{\omega T}{2}} \cdot 2\cos(\frac{\omega T}{2}) + e^{-j\frac{5\omega T}{2}} \cdot 2j\sin(\frac{\omega T}{2})
 \end{aligned}$$

Schwarz の不等式, $|x + y| \leq |x| + |y|$ より,

$$|H(\omega)| = |e^{-j\frac{\omega T}{2}} \cdot 2\cos(\frac{\omega T}{2}) + e^{-j\frac{5\omega T}{2}} \cdot 2j\sin(\frac{\omega T}{2})| \leq |e^{-j\frac{\omega T}{2}}| |2\cos(\frac{\omega T}{2})| + |e^{-j\frac{5\omega T}{2}}| |2j\sin(\frac{\omega T}{2})|$$

右辺を評価する.

$$|e^{-j\frac{\omega T}{2}}| |2\cos(\frac{\omega T}{2})| + |e^{-j\frac{5\omega T}{2}}| |2j\sin(\frac{\omega T}{2})| = 2\cos(\frac{\omega T}{2}) + 2\sin(\frac{\omega T}{2}) = 2\sqrt{2}\sin(\frac{\omega T}{2} + \frac{\pi}{4})$$

$$(\because |e^{-j\frac{\omega T}{2}}| = 1, |e^{-j\frac{5\omega T}{2}}| = 1, 0 \leq \omega T \leq \pi)$$

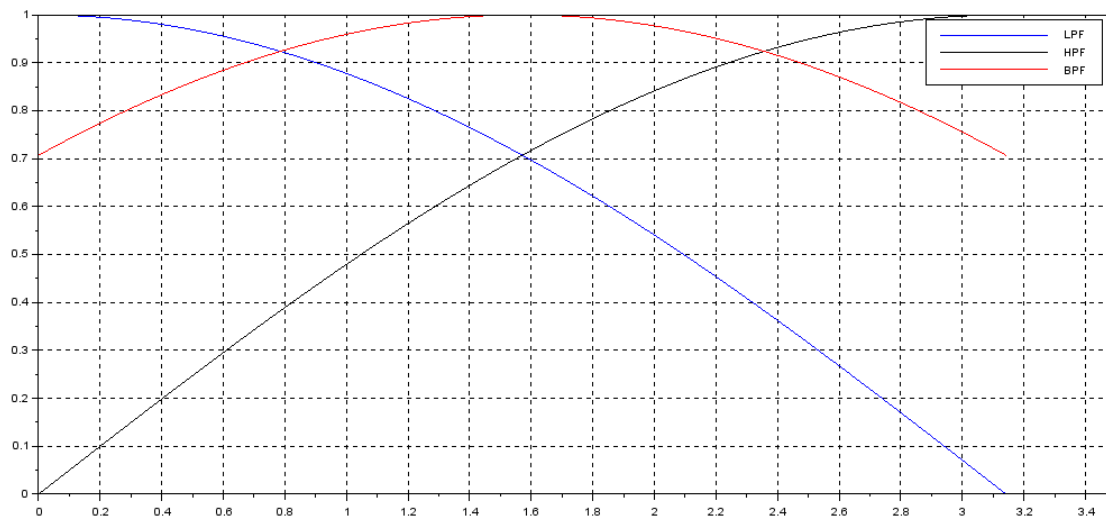

Source Code 1: Scilab

```

////////////////////////////////////
//      FIRフィルタ
//      FIR Filter
//
//              M.Tsutsui
////////////////////////////////////

clear;

//1次LPF
pi=%pi;
omega=0:pi/180:pi;
H_lpf=2*cos(omega/2);
plot(omega,H_lpf./max(H_lpf));

//1次HPF
H_hpf=2*sin(omega/2);
plot(omega,H_hpf./max(H_hpf),'k');

//3次BPF
H_bpf=2*sqrt(2)*sin(omega/2+pi/4);
plot(omega,H_bpf./max(H_bpf),'r');
xgrid();

legend(['LPF','HPF','BPF']);

```